



Verkeersmanagementplan N34

Verdubbeling N34 Emmen West – N381

Documentcode

[Redacted]

Status

Definitief

Datum

31-03-2020

Versie

3.0

Object

E0000 – Systeem
verdubbeling N34 Noord

Activiteittype

2.4 - Verkeersmanagement

Werkpakket

WP-200.104 – Opstellen
verkeersmanagementplan

Opgesteld: [Redacted] Functie: Projectvoorbereider	Gecontroleerd: [Redacted] Functie: Uitvoeringsmanager	Geautoriseerd: [Redacted] Functie: Projectmanager
Paraaf: [Redacted]	Paraaf: [Redacted]	Paraaf: [Redacted]
Datum: 31-03-2020	Datum: 31-03-2020	Datum: 31-03-2020



Wijzigingen

Versie	Omschrijving wijzigingen
3.0	Omleidingstekening Slenerweg, omleidingstekening 1 ^e weekendafsluiting N34, omleidingstekening 2 ^e weekendafsluiting N34 en omleidingstekening weekendafsluitingen N381 deels aangepast na opmerkingen Gemeente Coevorden en maatregel 19 (Barrier met zichtschermen op kunstwerken) toegevoegd.
2.0	Aanpassingen na toets Opdrachtgever
1.0	Eerste uitgave

Distributielijst

Organisatie	Projectrol	Aantal	Digitaal ja/nee
Provincie Drenthe	Opdrachtgever	1	Ja
Dura Vermeer Infra Regio Noord Oost	Opdrachtnemer	1	Ja

Projectgegevens

Contactgegevens Opdrachtnemer:

Dura Vermeer Infra Regio Noord Oost

Verdubbeling N34 Emmen West – N381

De heer [REDACTED]

Burgemeester Roelenweg 31

8031 ES Zwolle

Bezoekadres: Burgemeester Roelenweg 31, 8031 ES Zwolle

Contactgegevens Opdrachtgever:

Provincie Drenthe

Afdeling Wegen en Vaarwegen

De heer [REDACTED]

Postbus 122

9400 AC Assen

Bezoekadres: Westerbrink 1, 9405 BJ Assen

Contractnummer:

1662



■	
■	
■	
■	
■	
■	
■	

BIJLAGEN	29
-----------------------	----

.....	
-------	--

Bijlage II – Verkeersmaatregelentekening maatregel 1 t/m maatregel 3	33
--	----

.....	
-------	--

Bijlage IV – Verkeersmaatregelentekening maatregel 5	35
--	----

Bijlage V – Verkeersmaatregelentekening maatregel 6 en maatregel 7	36
--	----

.....	
-------	--

Bijlage VII – Verkeersmaatregelentekening maatregel 9 en 10	38
---	----

Bijlage VIII – Verkeersmaatregelentekening maatregel 11 en 12	39
---	----

.....	
-------	--

.....	
-------	--

.....	
-------	--

Bijlage XII – Verkeersmaatregelentekeningen maatregel 16	43
--	----

.....	
-------	--

.....	
-------	--

.....	
-------	--

.....	
-------	--

.....	
-------	--

.....	
-------	--



[Redacted]

[Redacted]

[Redacted]

1.1. Projectbeschrijving

[Redacted]







[Redacted content]



[Redacted content]

- [Redacted list item]
- [Redacted list item]

[Redacted content]

[Redacted content]

- [Redacted list item]
- [Redacted list item]
- [Redacted list item]
- [Redacted list item]
- [Redacted list item]
- [Redacted list item]
- [Redacted list item]
- [Redacted list item]
- [Redacted list item]

[Redacted content]

- [Redacted list item]

[Redacted content]

- [Redacted list item]



[Redacted text block]



[Redacted text block]



[Redacted content]



[Redacted content]



[Redacted text block]

- [Redacted list item]
- [Redacted list item]
- [Redacted list item]
- [Redacted list item]
- [Redacted list item]
- [Redacted list item]
- [Redacted list item]
- [Redacted list item]
- [Redacted list item]
- [Redacted list item]





[Redacted content]



[Redacted content]



[Redacted text block containing multiple lines of greyed-out content, including a bulleted list and several paragraphs.]



[Redacted text block containing multiple lines of greyed-out content, including a bulleted list item.]



[Redacted content]



[Redacted content]



[Redacted text block containing multiple lines of greyed-out content, including bulleted points and paragraph structures.]



[Redacted text block containing multiple lines of greyed-out content, including bulleted points and paragraph structures.]



[Redacted content]



[Redacted text block]

[Redacted text block]

[Redacted text block]

[Redacted text block]

[Redacted text block]

[Redacted text block]

[Redacted text block]



[Redacted content]



BIJLAGEN



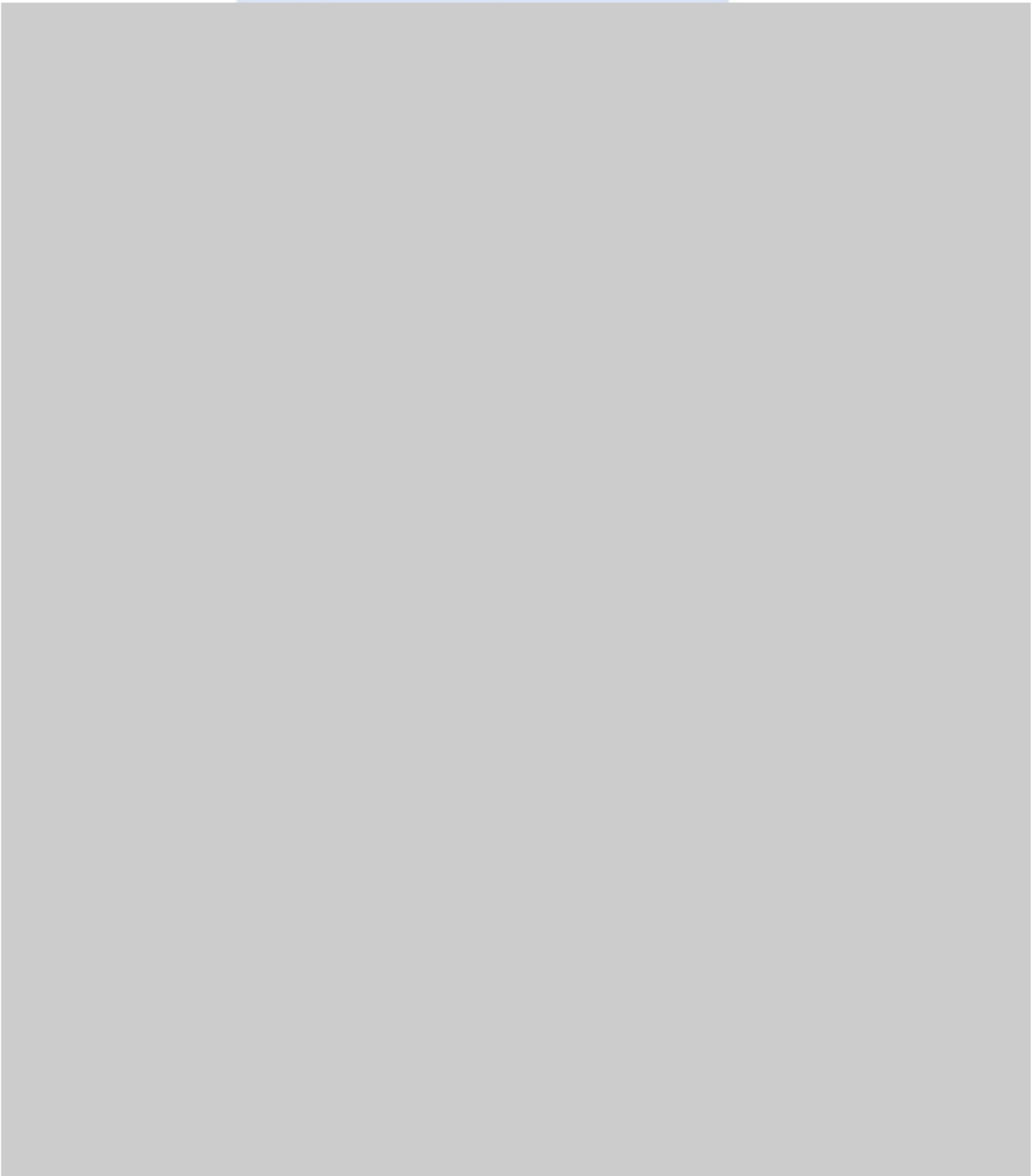





Bijlage II – Verkeersmaatregelentekening maatregel 1 t/m maatregel 3

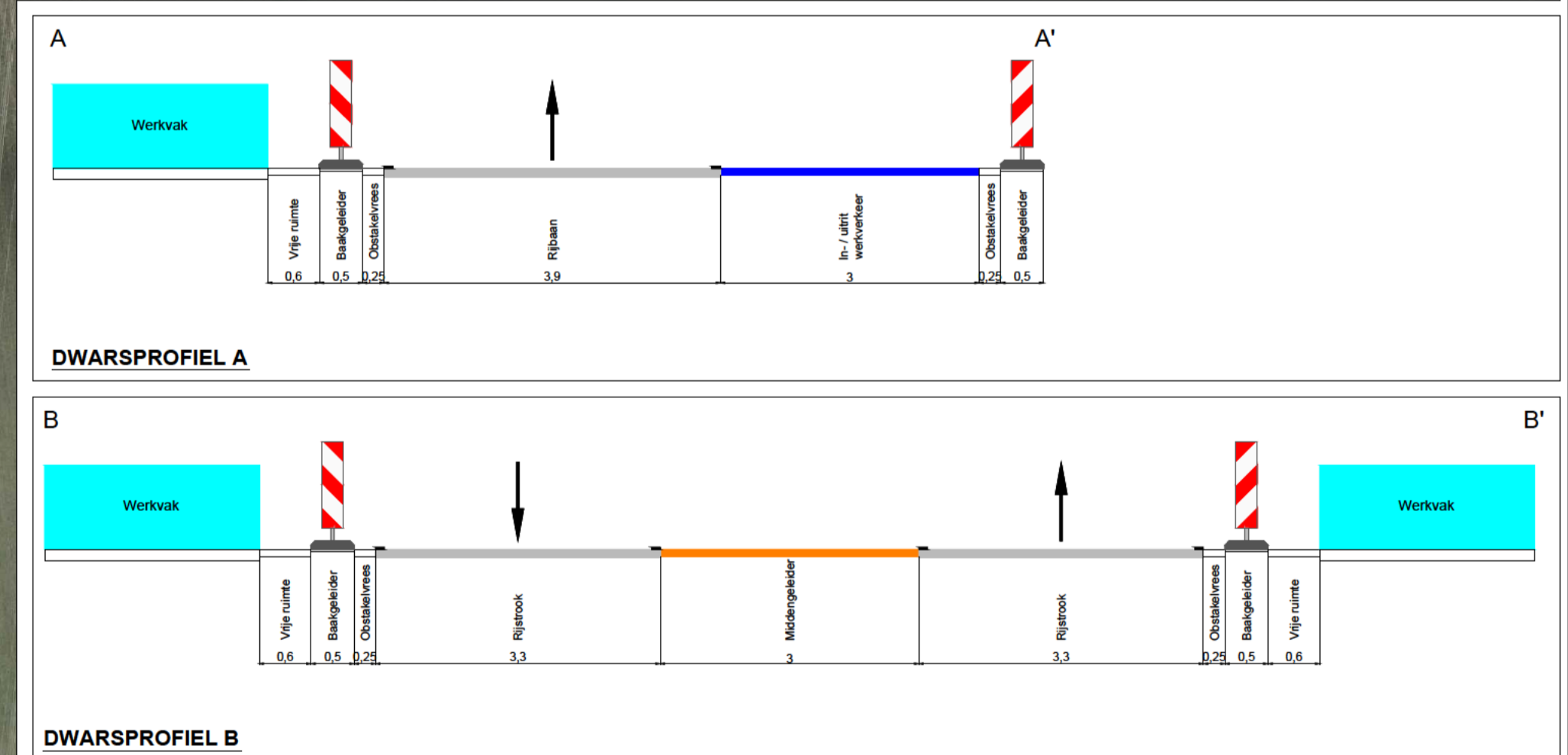
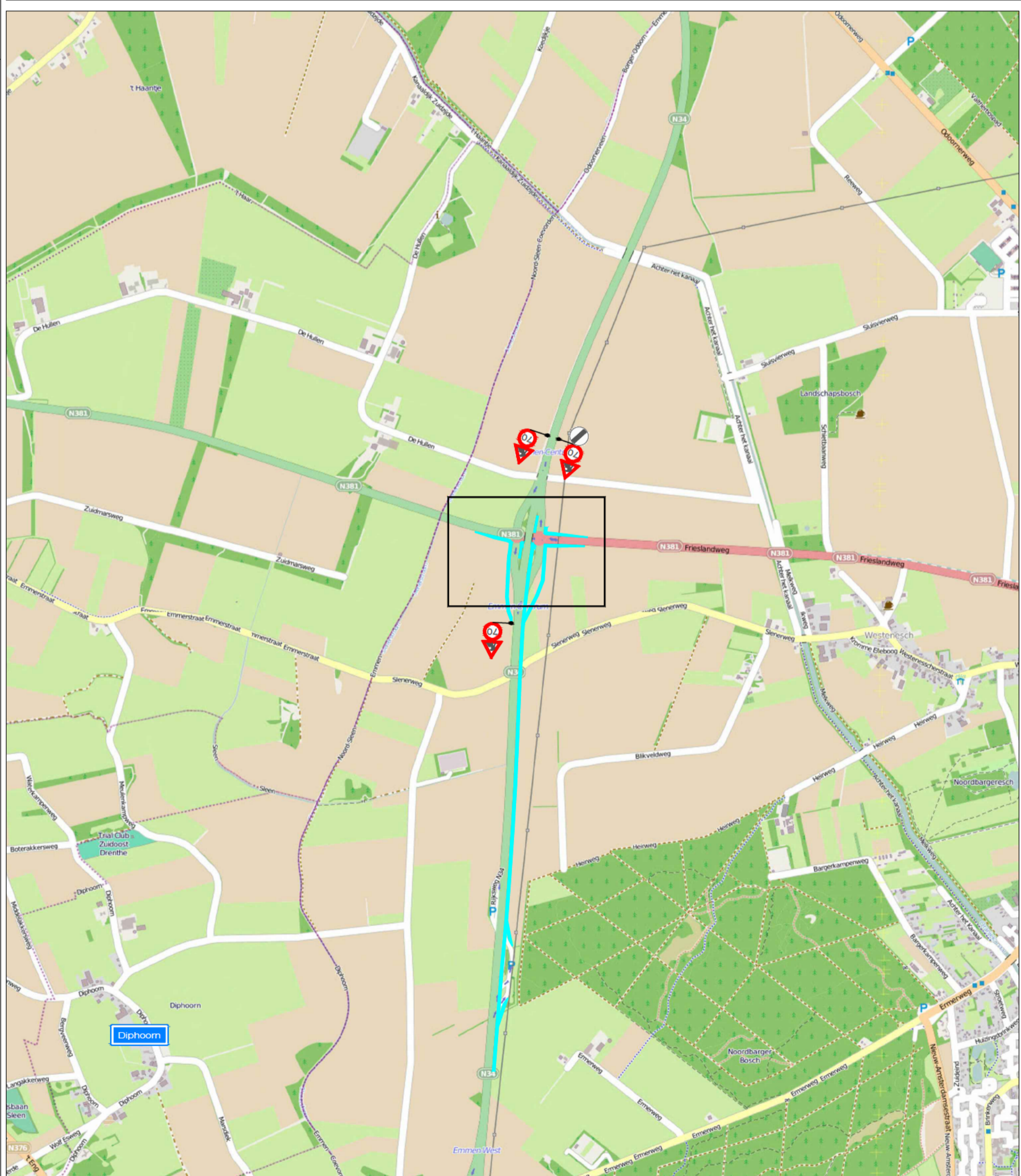

- LEGENDA**
- Werkvak
 - In- / uitrit werkverkeer
 - Alle bebording klasse 2
 - Lettertype bebording ANWB Uu
 - Letterhoogte Bibeko 10 cm
 - Letterhoogte Bubeko 16 cm
 - Letterhoogte Autosnelweg 30 cm
 - Conflicterende bebording afplakken

OPDRACHTGEVER:		DATE:	05-09-2019	INDAAG:	
PROJECT:	Verdubbeling N34, Emmen West - Aansluiting N381 In-/uitritten werkverkeer Fase 1a Knp. N34 - N381	GEZ.:	05-09-2019		
		VERD.	10-02-2020		
		WKS:	B		
				DEFINITIEF	
		PROJECT NR.:	B19-00953	SCHAAL:	NVT
		TEKENING NR.:	STN03	FORMAAT:	A1

Vestiging Rijssen: Fahrheitstraat 13
7461 JA RIJSSEN

Vestiging Beilen: De Hanekampen 17
9411 XN BEILEN

Tel.: +31 (0)548 82 09 90
info@savetrafficnederland.nl
www.savetrafficnederland.nl

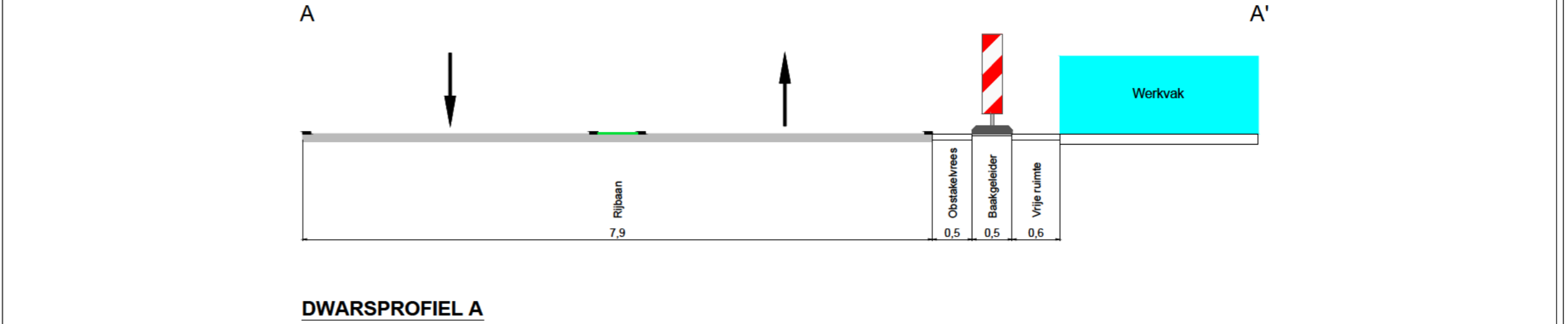
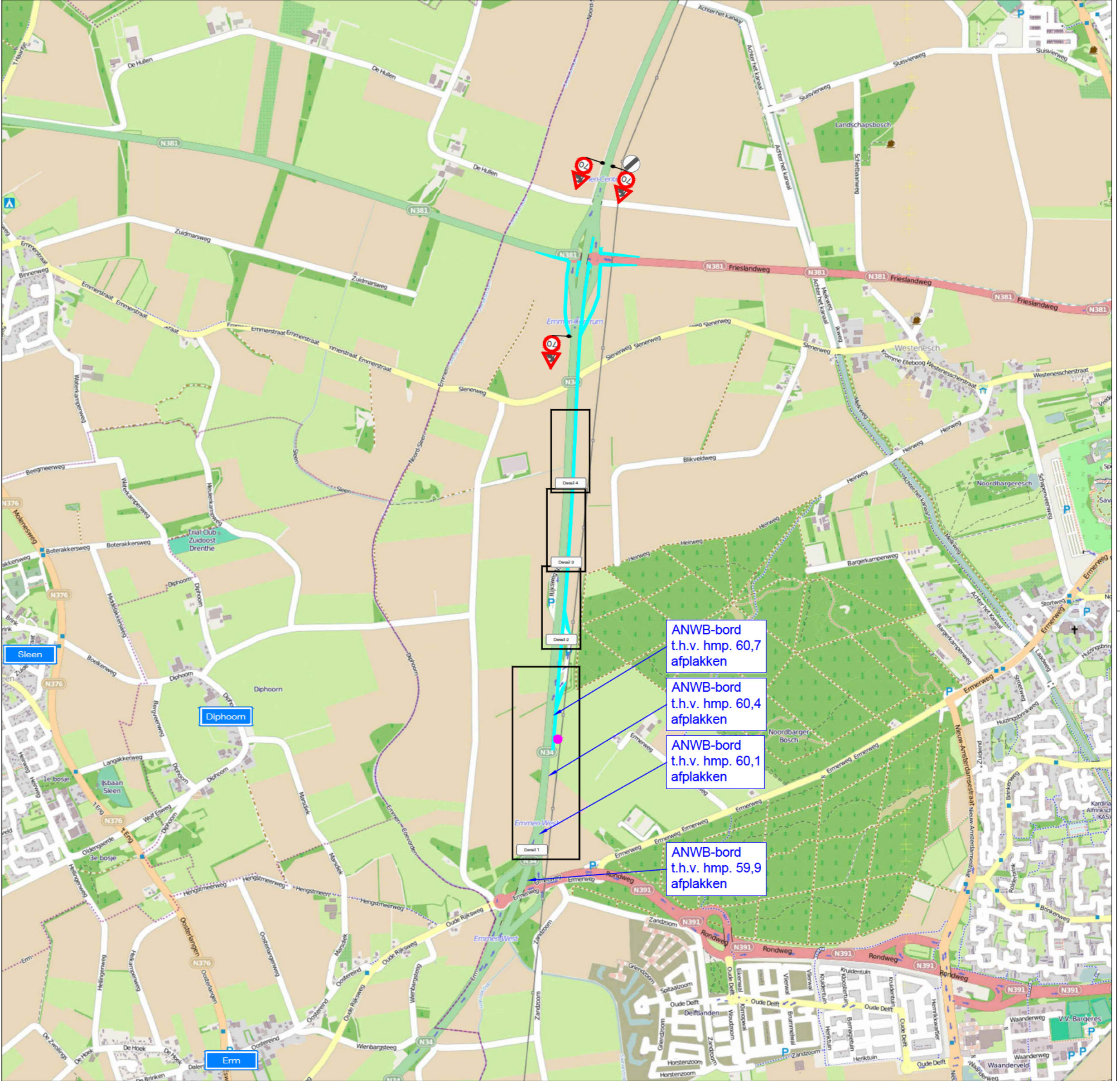
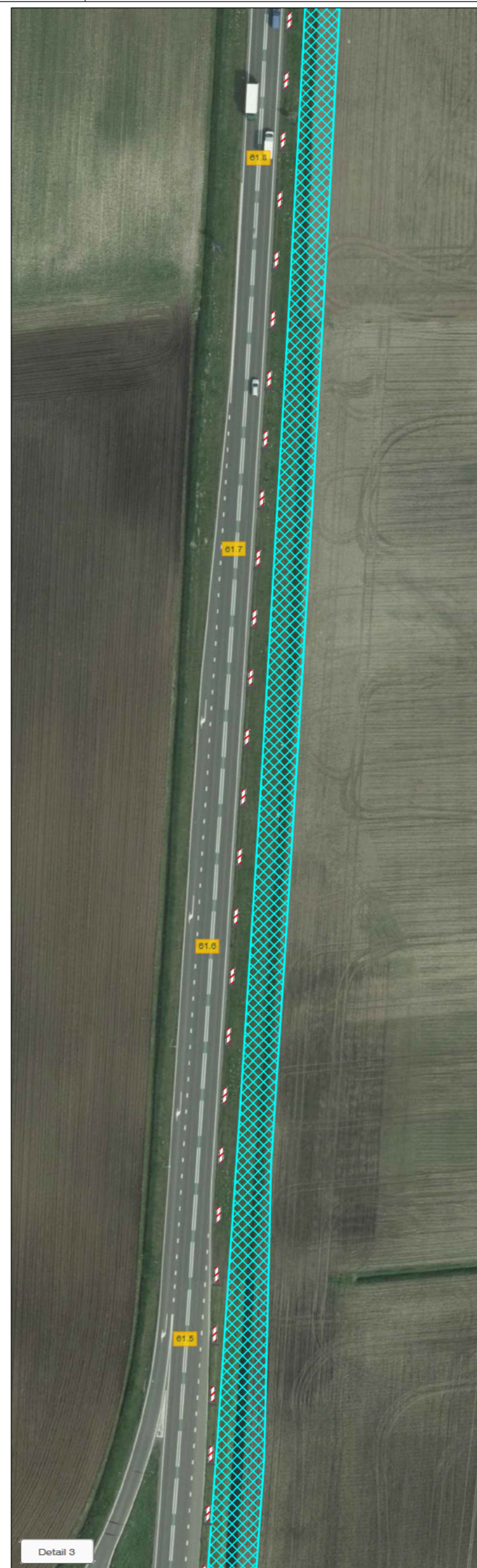
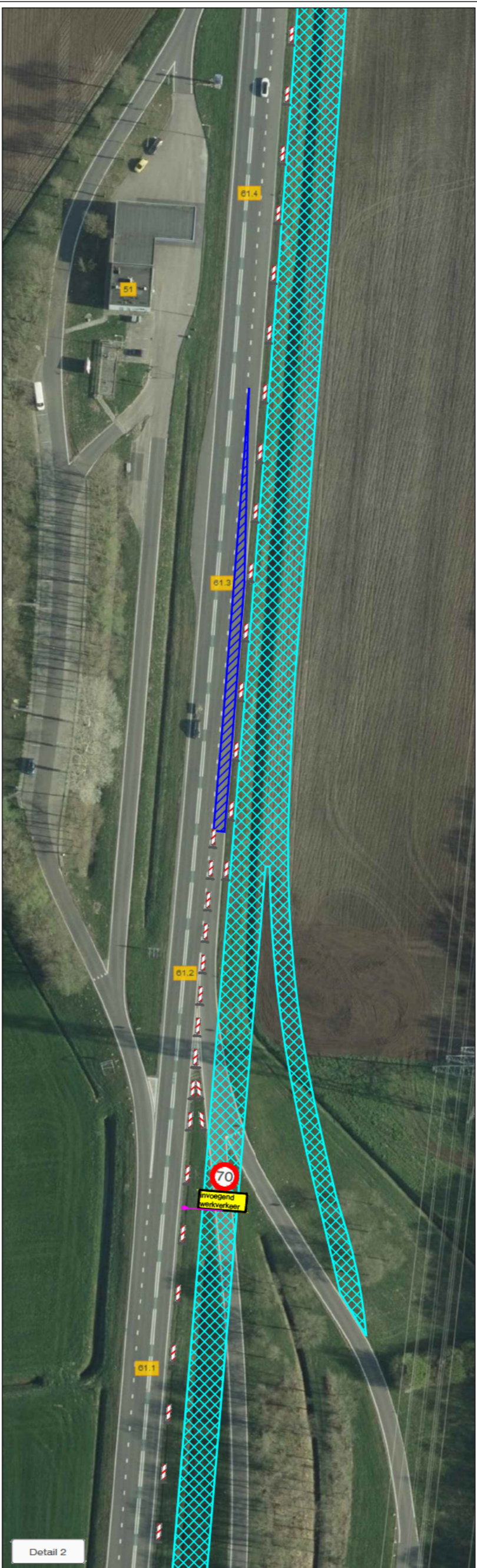
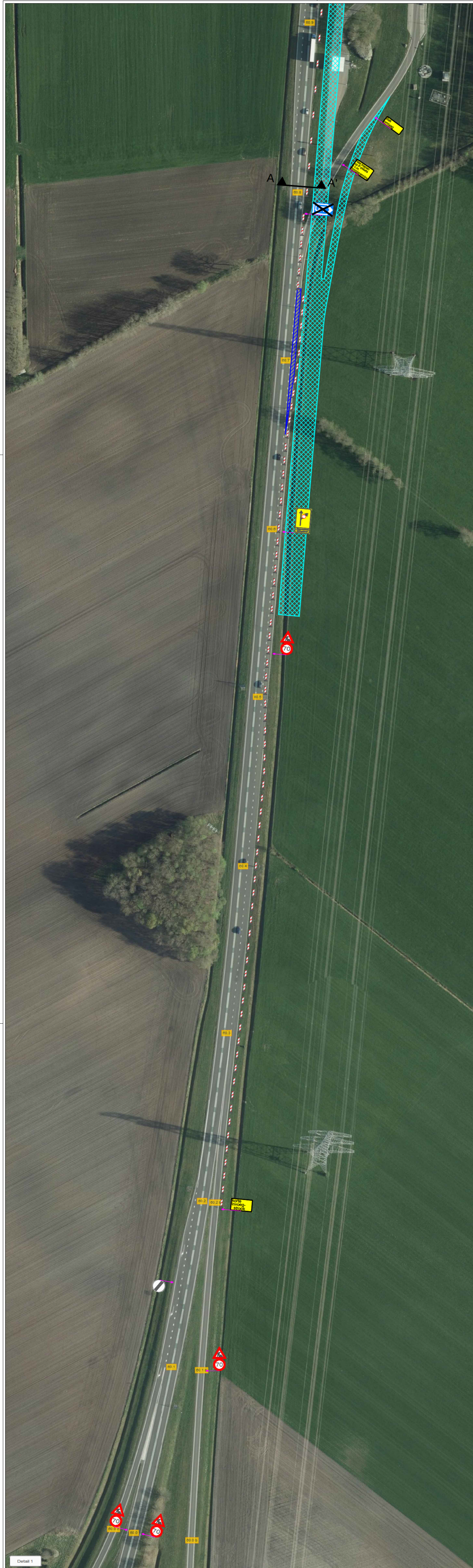

- LEGENDA**
- Werkvak
 - In- / uitrit werkverkeer
 - Alle bebording klasse 2
 - Lettertype bebording ANWB Uu
 - Letterhoogte Bibeko 10 cm
 - Letterhoogte Bubeko 16 cm
 - Letterhoogte Autosnelweg 30 cm
 - Conflicterende bebording afplakken

VOORAANKONDIGING
(2 weken van tevoren)

PA
Westerveld
afgesloten
vanaf 3-2

OPDRACHTGEVER: **DURA VERMEER**
Waarmaken van ambities

PROJECT: Verdubbeling N34, Emmen West - Aansluiting N381
In-/uitritten werkverkeer Fase 1a | P-Westerveld

Vestiging Rijssen: De Hanekepen 13, 7461 JA RIJSSSEN
Vestiging Bellen: De Hanekepen 17, 9411 XN BELLEN
Tel.: +31 (0)548 82 09 90
info@savetrafficnederland.nl
www.savetrafficnederland.nl

OPDRACHTGEVER:	DATE:	PARAAF:
PROJECT:	GET: 27-08-2019	
	GEZ: 27-08-2019	
	WES: 23-01-2020	
	DEFINITIEF	
	PROJECT NR: B19-00953	SCHAAL: NVT
	TEKENING NR: STN04	FORMAAT: A1

STN Save Traffic Nederland
Advies, ontwerp en uitvoering tijdelijke verkeersmaatregelen







Bijlage IV – Verkeersmaatregelentekening maatregel 5

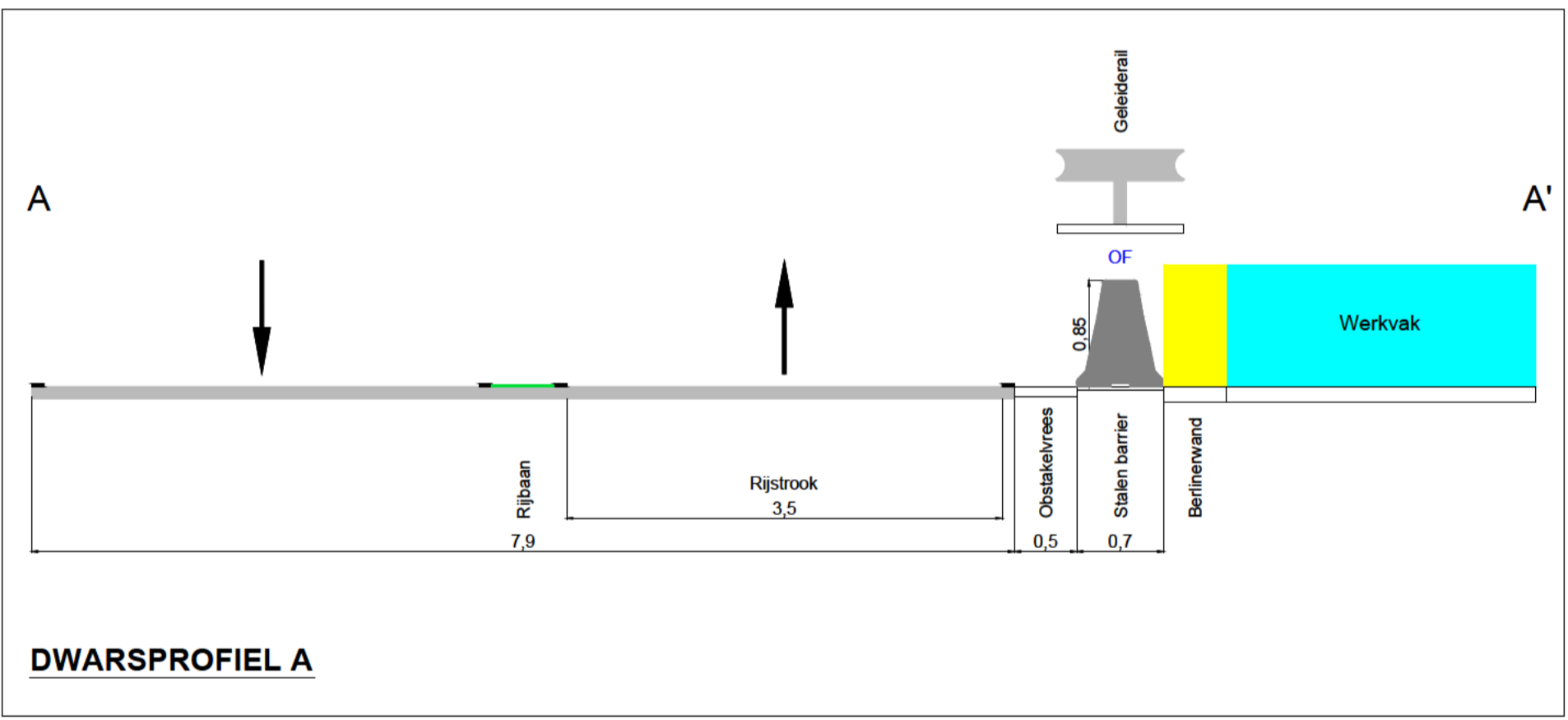
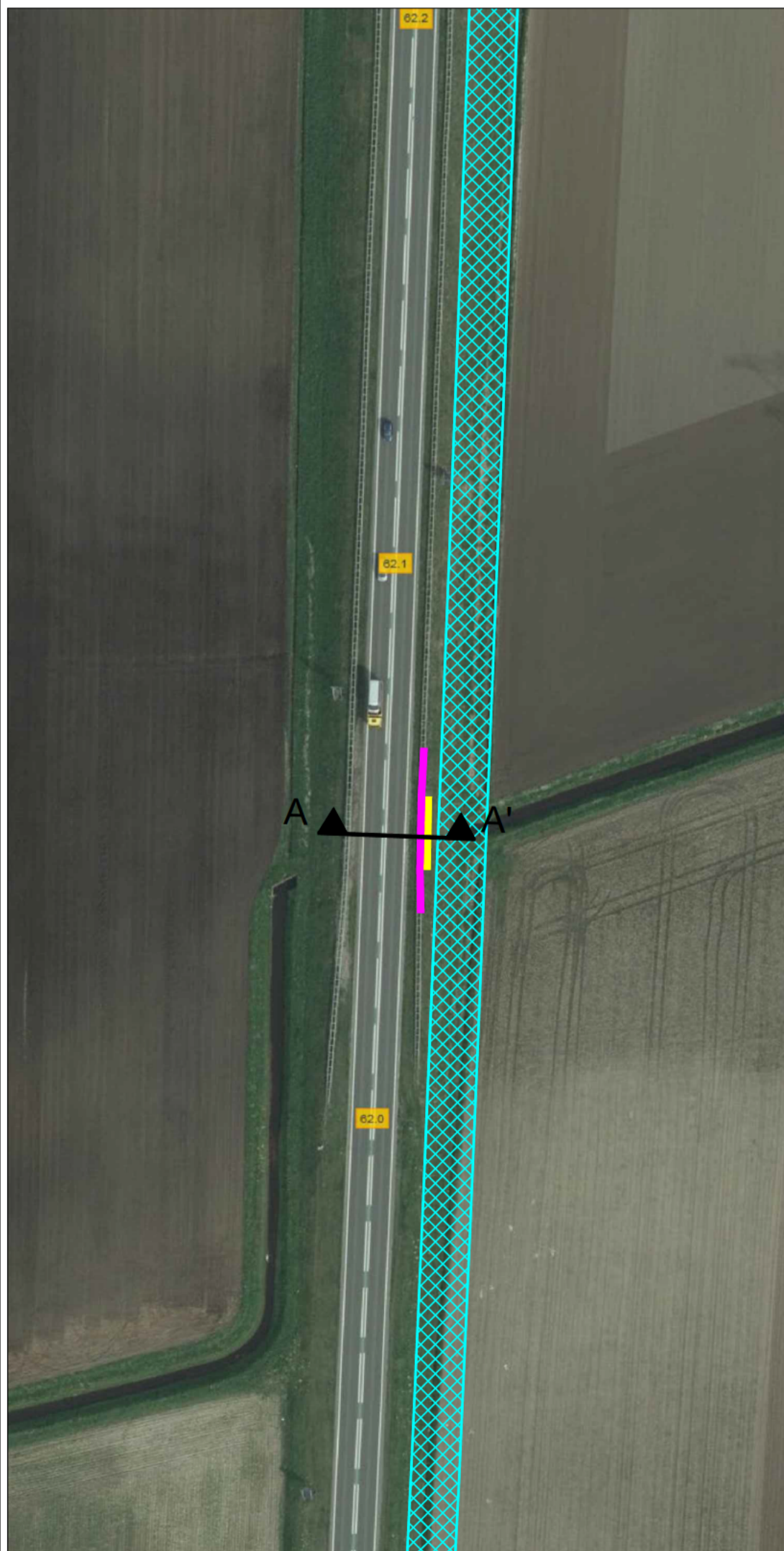
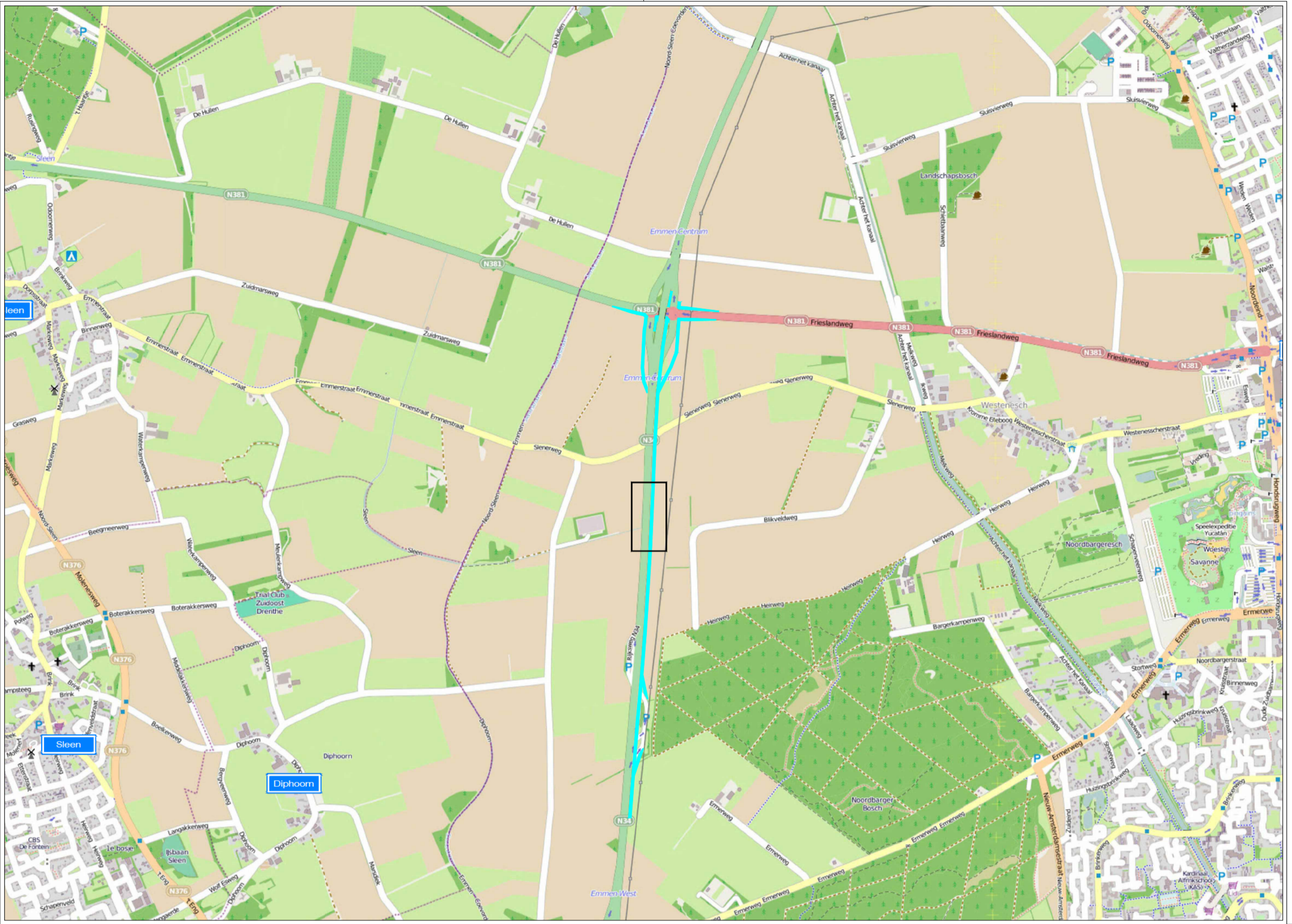

LEGENDA

- Werkvak
- Berlinerwand (Dura Vermeer)
- Barriër / geleiderail
- Alle bebording klasse 2
- Lettertype bebording ANWB Uu
- Letterhoogte Bibeko 10 cm
- Letterhoogte Bubeko 16 cm
- Letterhoogte Autosnelweg 30 cm
- Conflicterende bebording afplakken

OPDRACHTGEVER:	DURA VERMEER Waarmaken van ambities	Buiten reikwijdte	DATUM:	PARAAF:
PROJECT:	Verdubbeling N34, Emmen West - Aansluiting N381 Maatregel 5 Afzetting t.b.v. Berlinerwand aanleg duik		18-10-2019	
Vestiging Rijssen: Fahrenheitstraat 13 7461 JA RIJSSSEN	Vestiging Beilen: De Hanekampen 17 9411 XN BEILEN	Tel.: +31 (0)548 82 09 90 info@savetrafficnederland.nl www.savetrafficnederland.nl	19-00953	SCHAAL: NVT
			STN06	FORMAAT: A2

STN Save Traffic Nederland

Save Traffic Nederland

Advies, ontwerp en uitvoering tijdelijke verkeersmaatregelen



Bijlage V – Verkeersmaatregelentekening maatregel 6 en maatregel 7

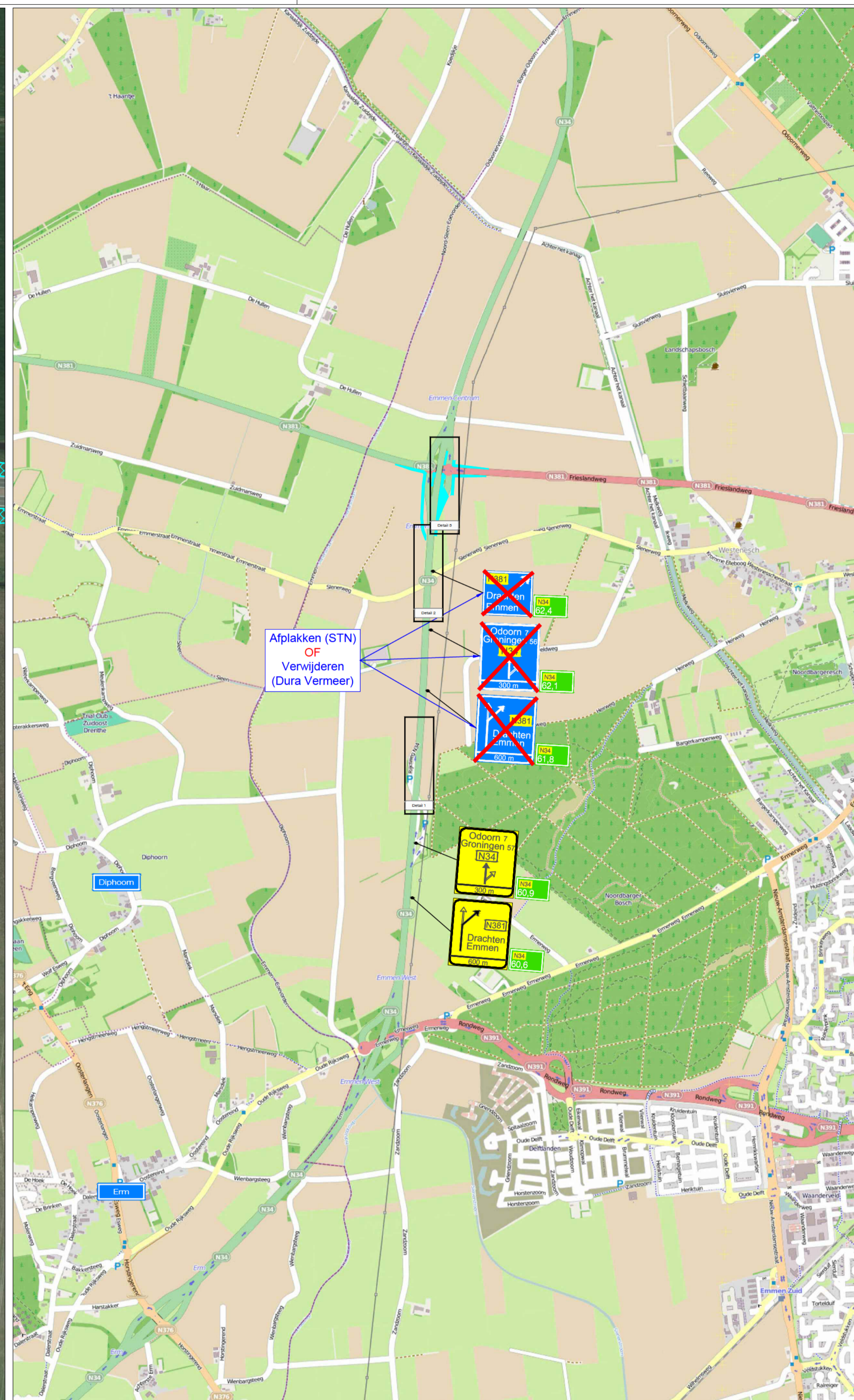
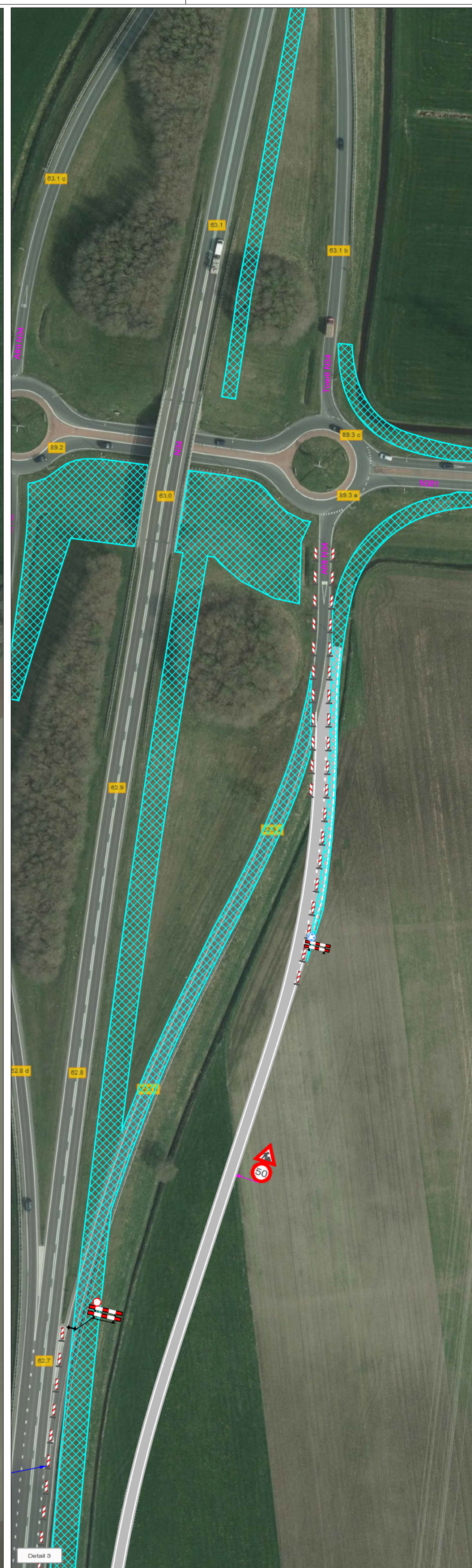
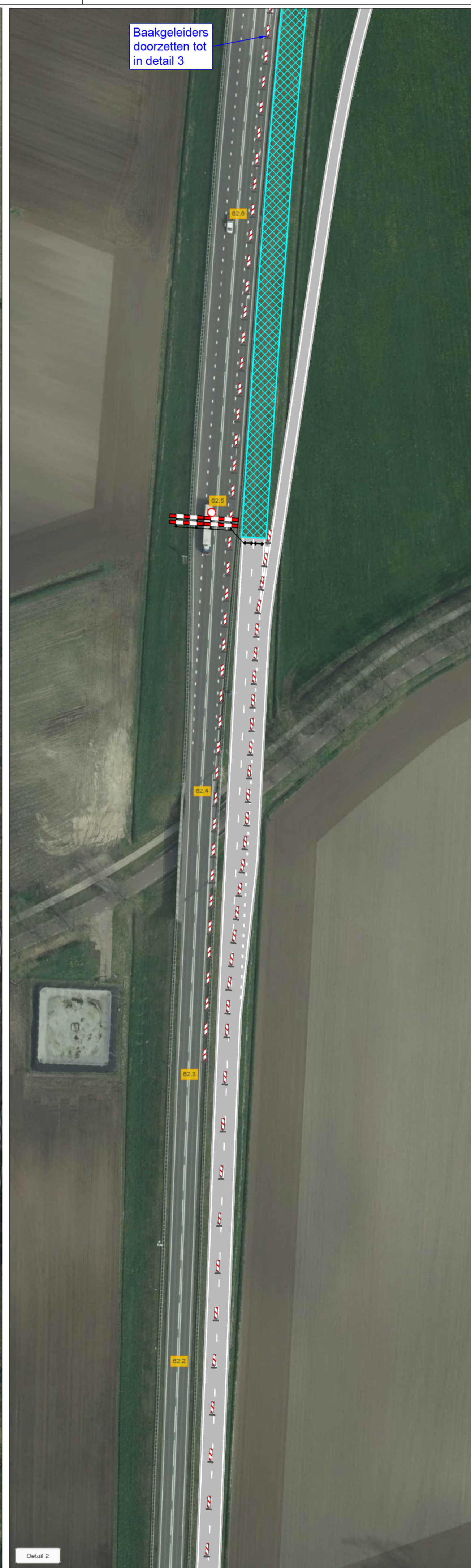
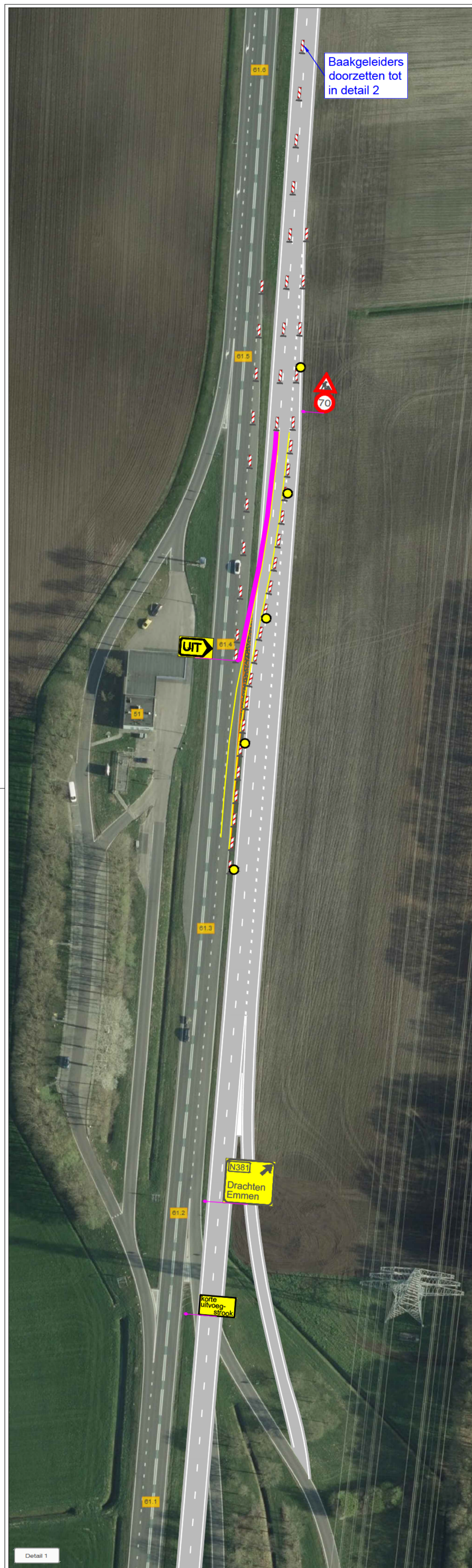

- LEGENDA**
- Werkvak
 - Nieuwe situatie
 - Tijdelijke verharding (Dura Vermeer)
 - Tijdelijke markering (door derden)
 - Barier
 - Tijdelijke verlichting
 - Alle bebording klasse 2
 - Lettertype bebording ANWB Uu
 - Letterhoogte Bibeko 10 cm
 - Letterhoogte Bubeko 16 cm
 - Letterhoogte Autosnelweg 30 cm
 - Conflicterende bebording afplakken

OPDRACHTGEVER:	Buizen reikwijdte	DATE:	PARAAF:
PROEFT:	Verdubbeling N34, Emmen West - Aansluiting N381	24-10-2019	
	Maatregel 6 & 7 Tijdelijke afrit N381	24-10-2019	
Vestiging Rijssen: Fahrenhetstraat 13 7461 JA RIJSSEN	Vestiging Beilen: De Haneekampen 17 9411 XN BEILEN	Tel.: +31 (0)548 82 09 90 info@savetrafficnederland.nl www.savetrafficnederland.nl	
STN Save Traffic Nederland		19-00953	SCHAAL: NVT
		STN07	FORMAAT: A1



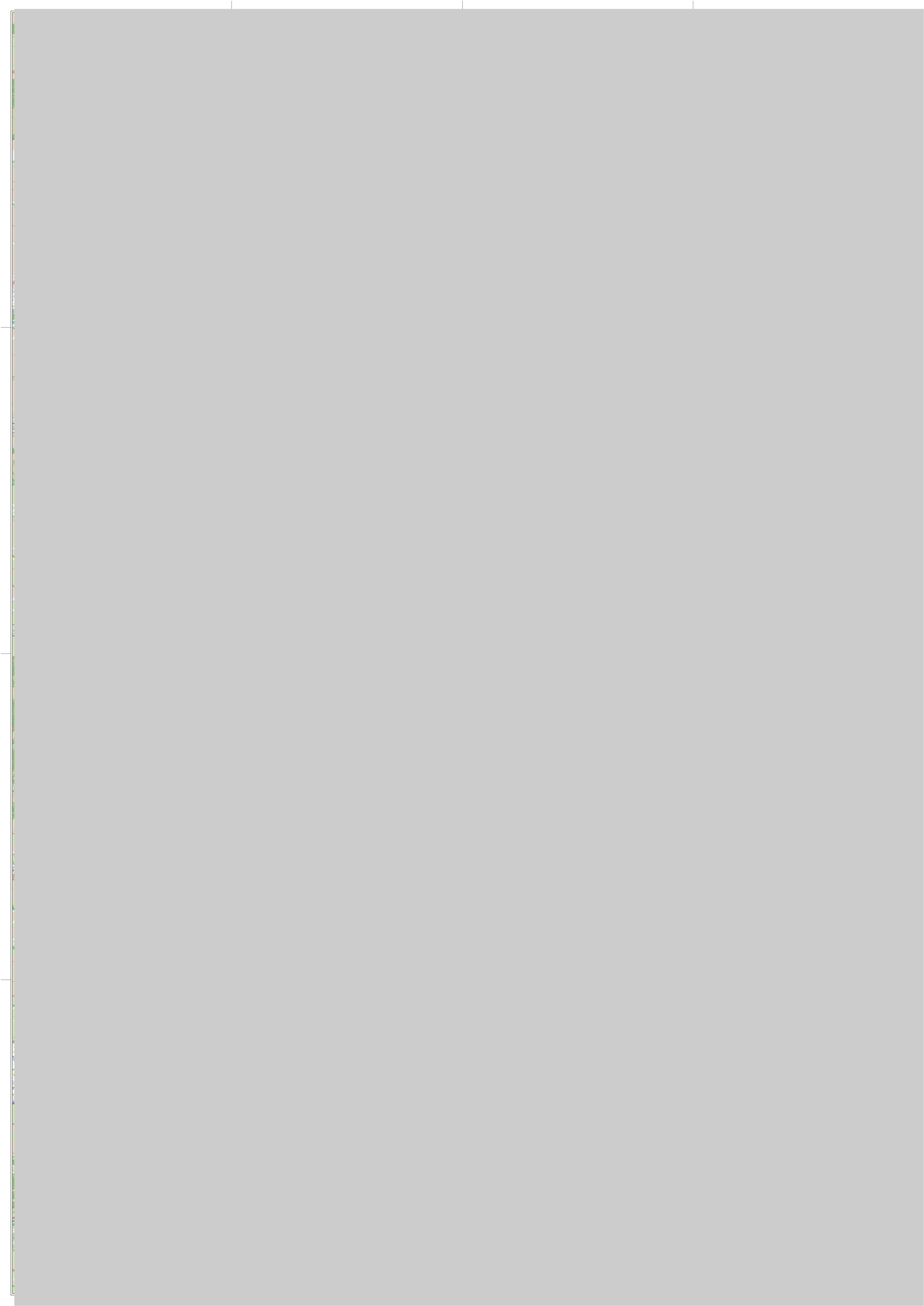

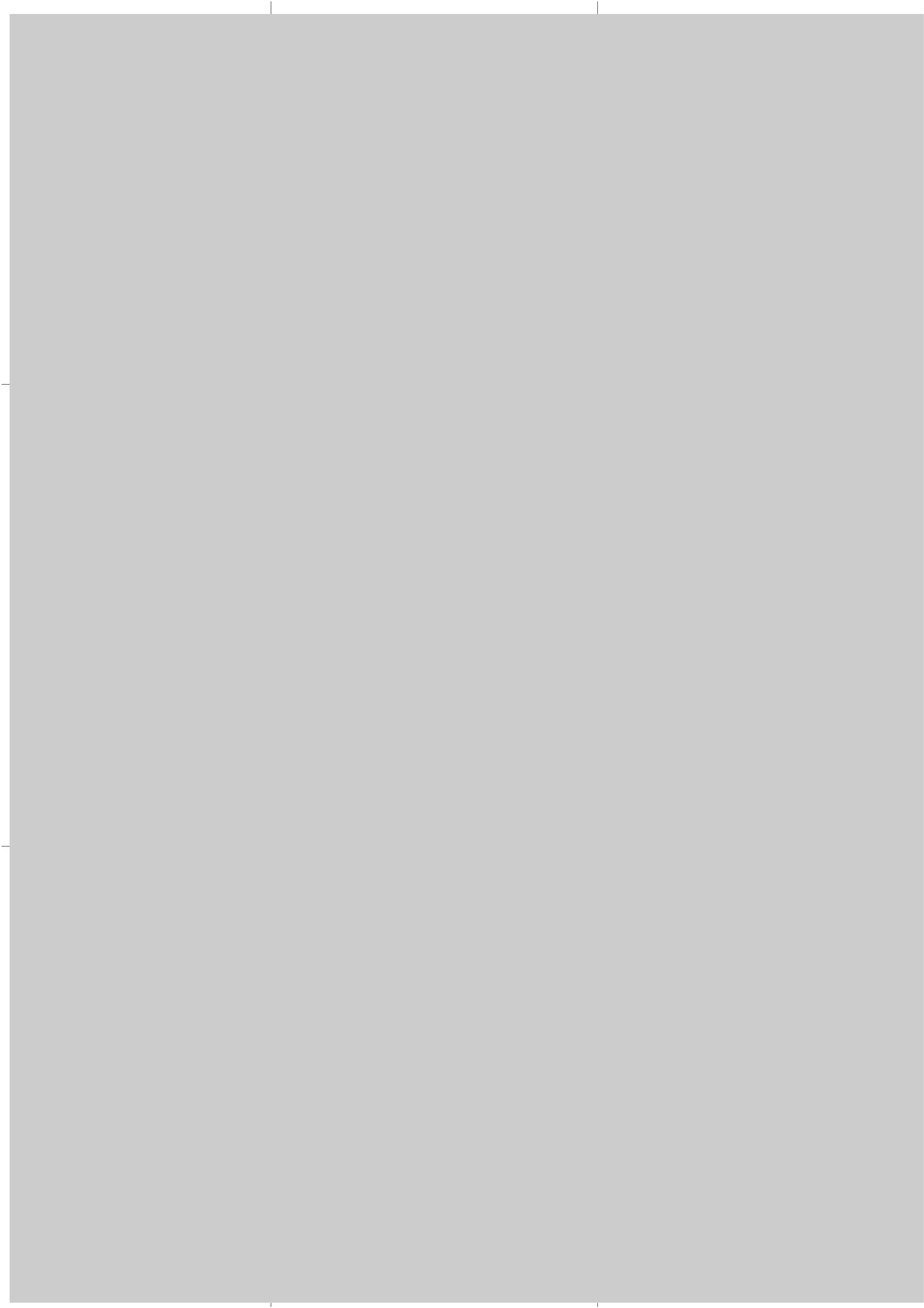



Bijlage VII – Verkeersmaatregelentekening maatregel 9 en 10

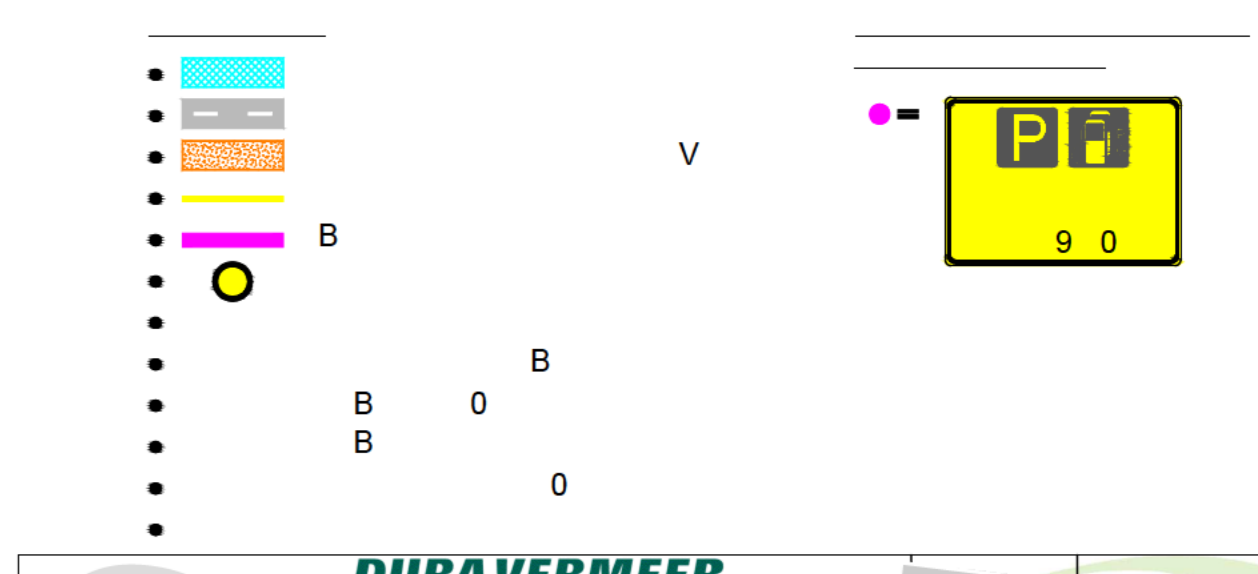
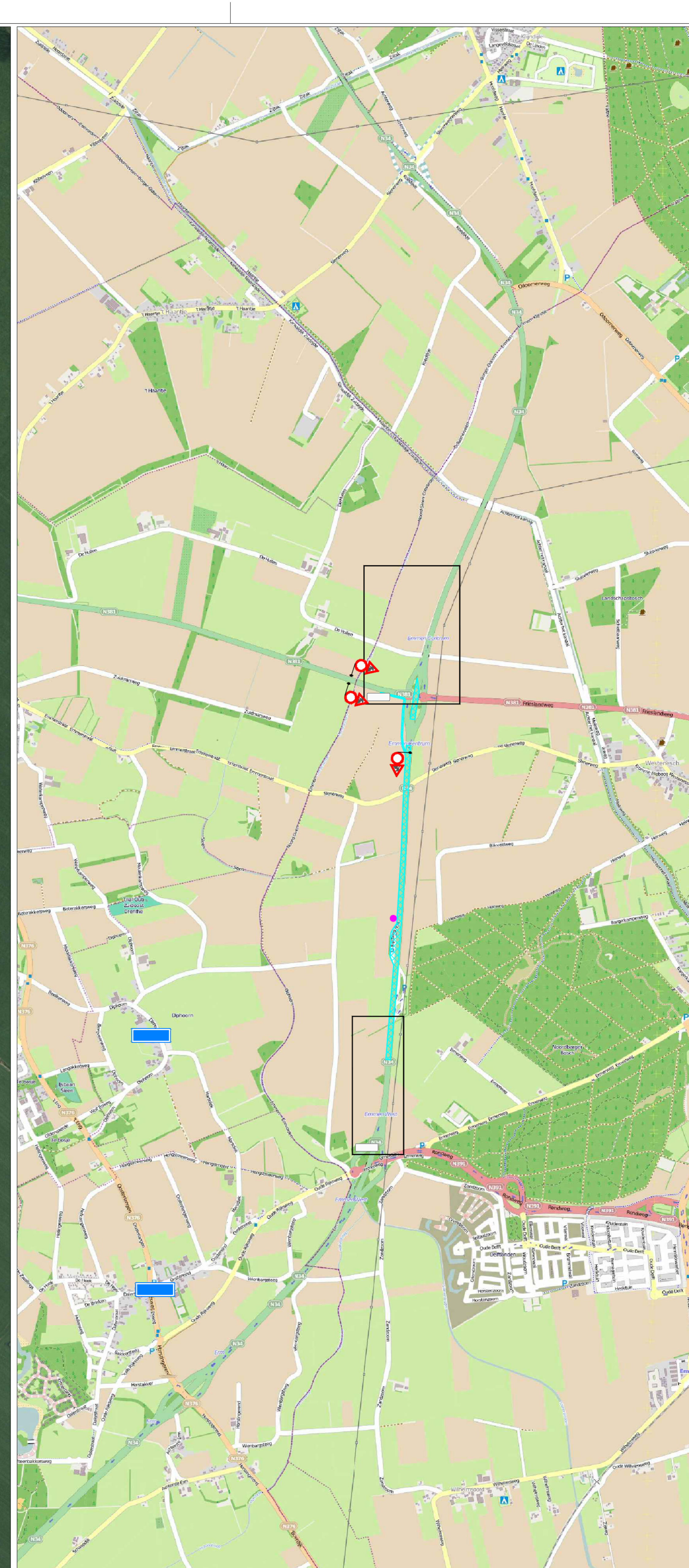
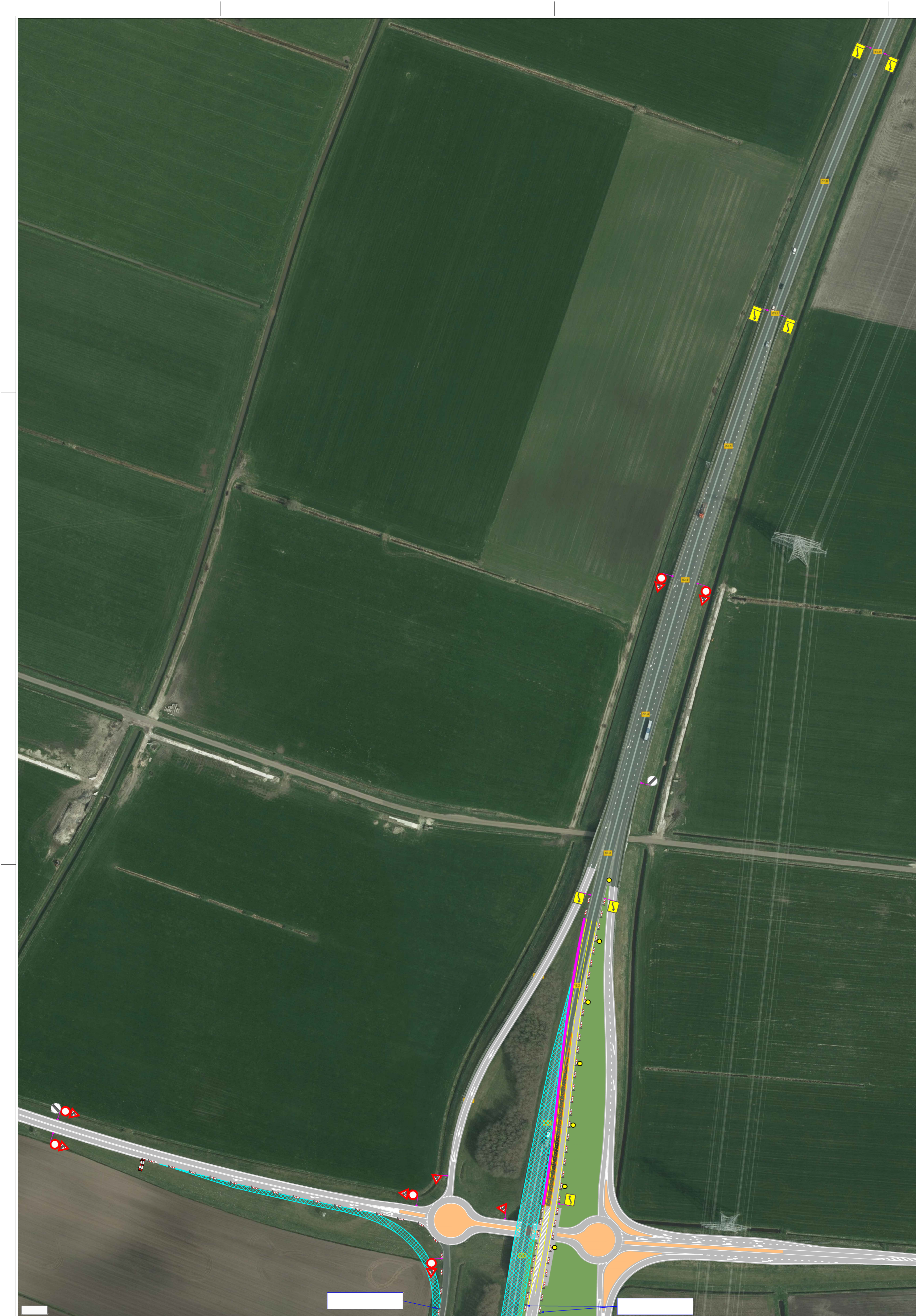



Bijlage VIII – Verkeersmaatregelentekening maatregel 11 en 12

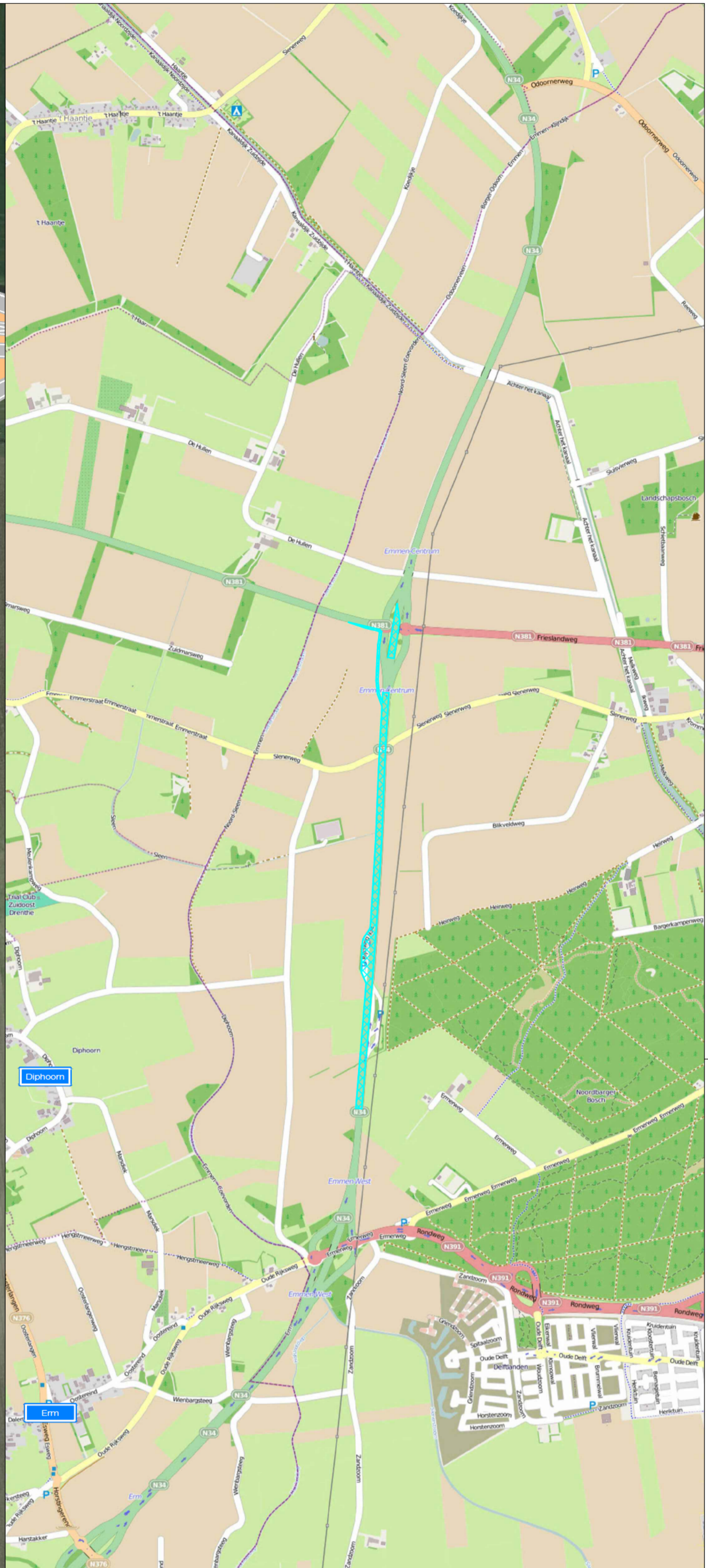
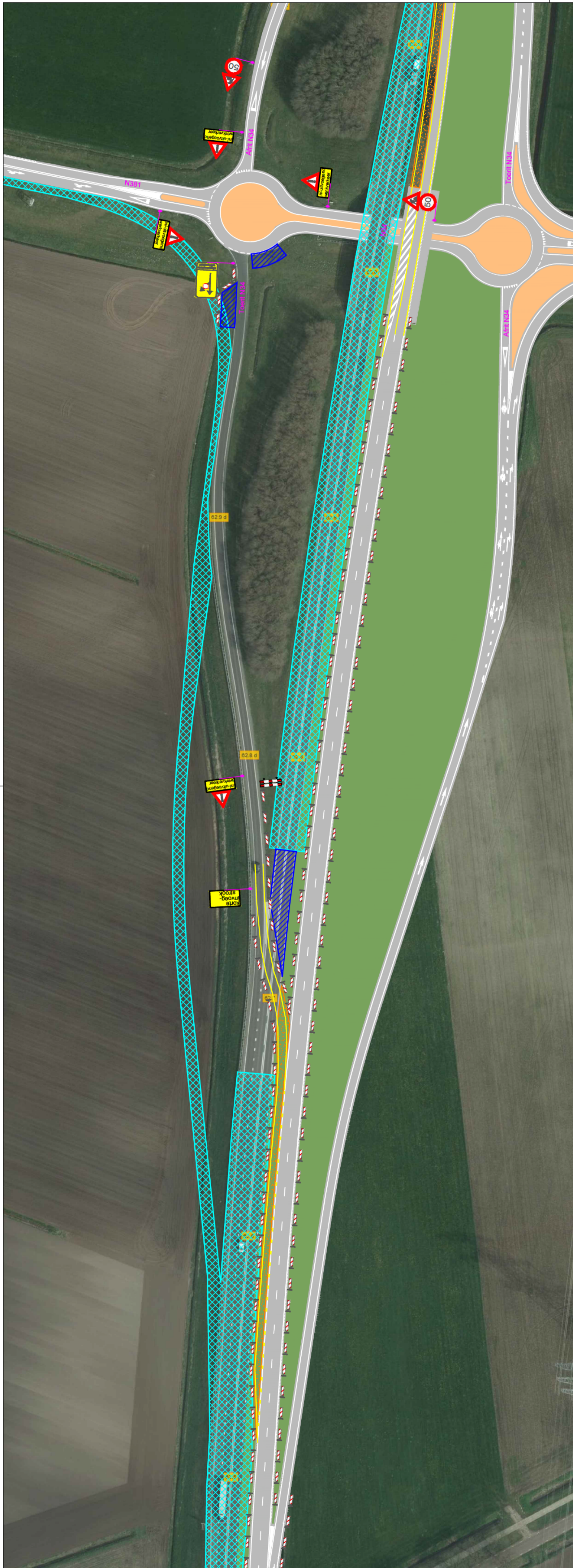

LEGENDA

- Werkvak
- In- / uitrit werkverkeer
- Nieuwe situatie
- Tijdelijke verharding (Dura Vermeer)
- Tijdelijke marking (door derden)
- Alle bebodding klasse 2
- Lettertype bebodding ANWB Uu
- Letterhoogte Bibeko 10 cm
- Letterhoogte Bubeko 16 cm
- Letterhoogte Autosnelweg 30 cm
- Conflicterende bebodding afplakken

OPDRACHTGEVER:	 DURA VERMEER Buiten reikwijdte Waarmaken van ambities	OPDRACHTGEVER:	Buiten reikwijdte						
PROJECT:	Verdubbeling N34, Emmen West - Aansluiting N381 Maatregel 11 & 12 Verlengen toerit N381 + in-/uitrit werkverkeer	OPDRACHTGEVER:	Buiten reikwijdte						
Vestiging Rijssen: Fahrenheitstraat 13 7461 JA RIJSSSEN	Vestiging Beilen: De Hanekampen 17 9411 XN BEILEN	Tel.: +31 (0)548 82 09 90 info@savetrafficnederland.nl www.savetrafficnederland.nl	<table border="1"> <tr> <td>DATUM:</td> <td>PARAAF:</td> </tr> <tr> <td>18-10-2019</td> <td></td> </tr> <tr> <td>18-10-2019</td> <td></td> </tr> </table>	DATUM:	PARAAF:	18-10-2019		18-10-2019	
DATUM:	PARAAF:								
18-10-2019									
18-10-2019									
<table border="1"> <tr> <td>19-00953</td> <td>SCHAAL:</td> <td>NVT</td> </tr> <tr> <td>STN10</td> <td>FORMAAT:</td> <td>A2</td> </tr> </table>			19-00953	SCHAAL:	NVT	STN10	FORMAAT:	A2	© Opschriftrechten systeem
19-00953	SCHAAL:	NVT							
STN10	FORMAAT:	A2							

 **Save Traffic Nederland**
Advies, ontwerp en uitvoering tijdelijke verkeersmaatregelen



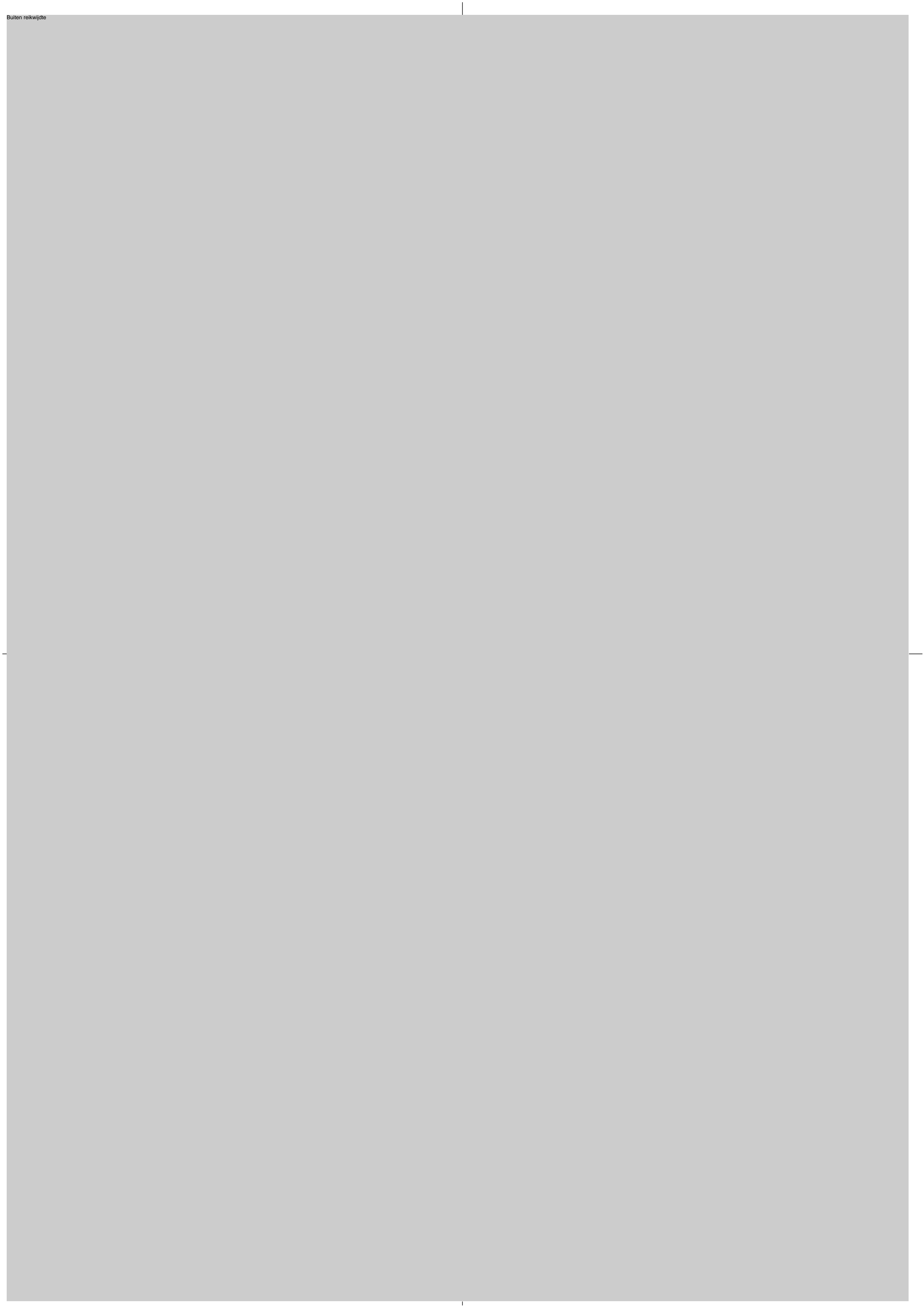



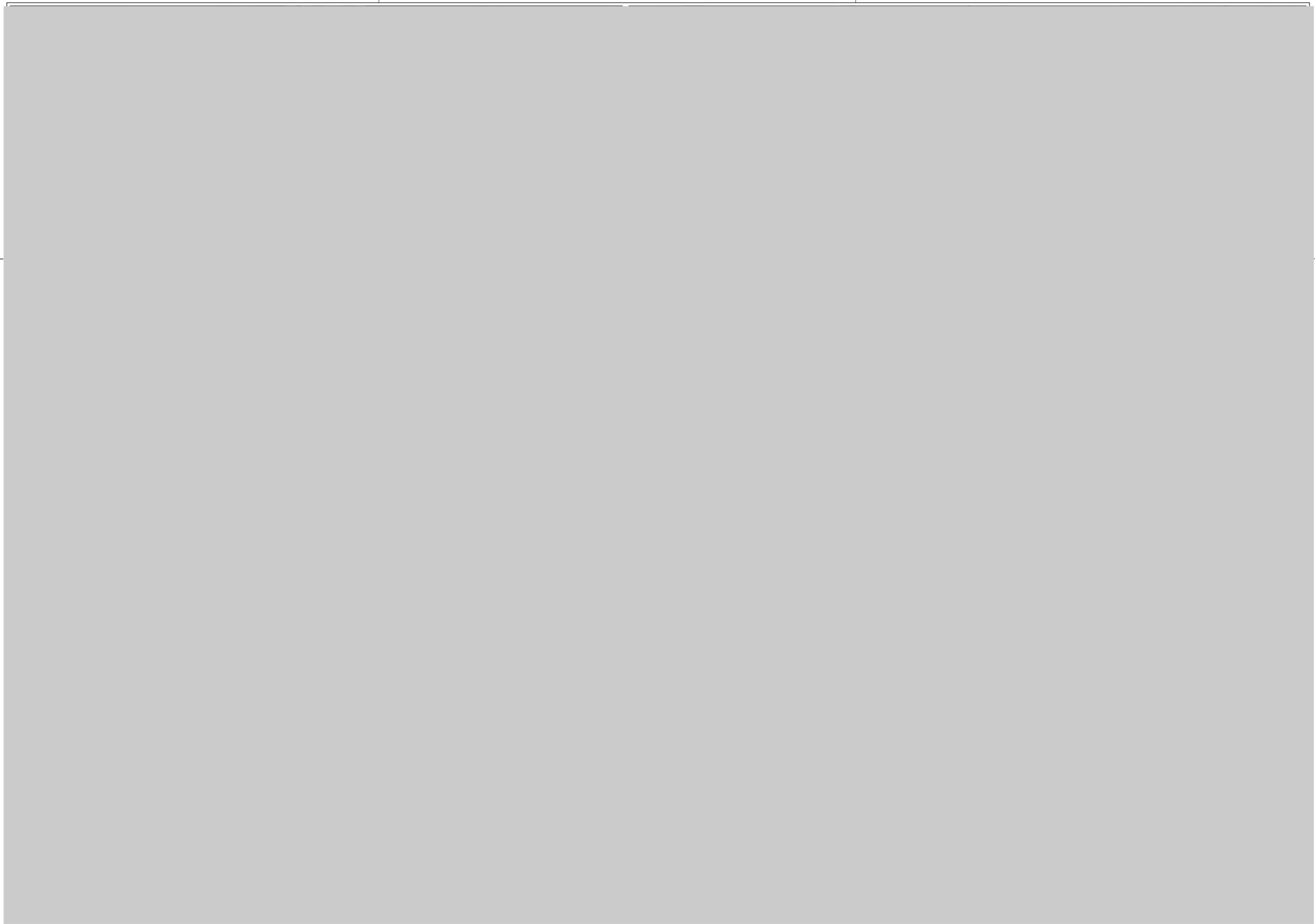



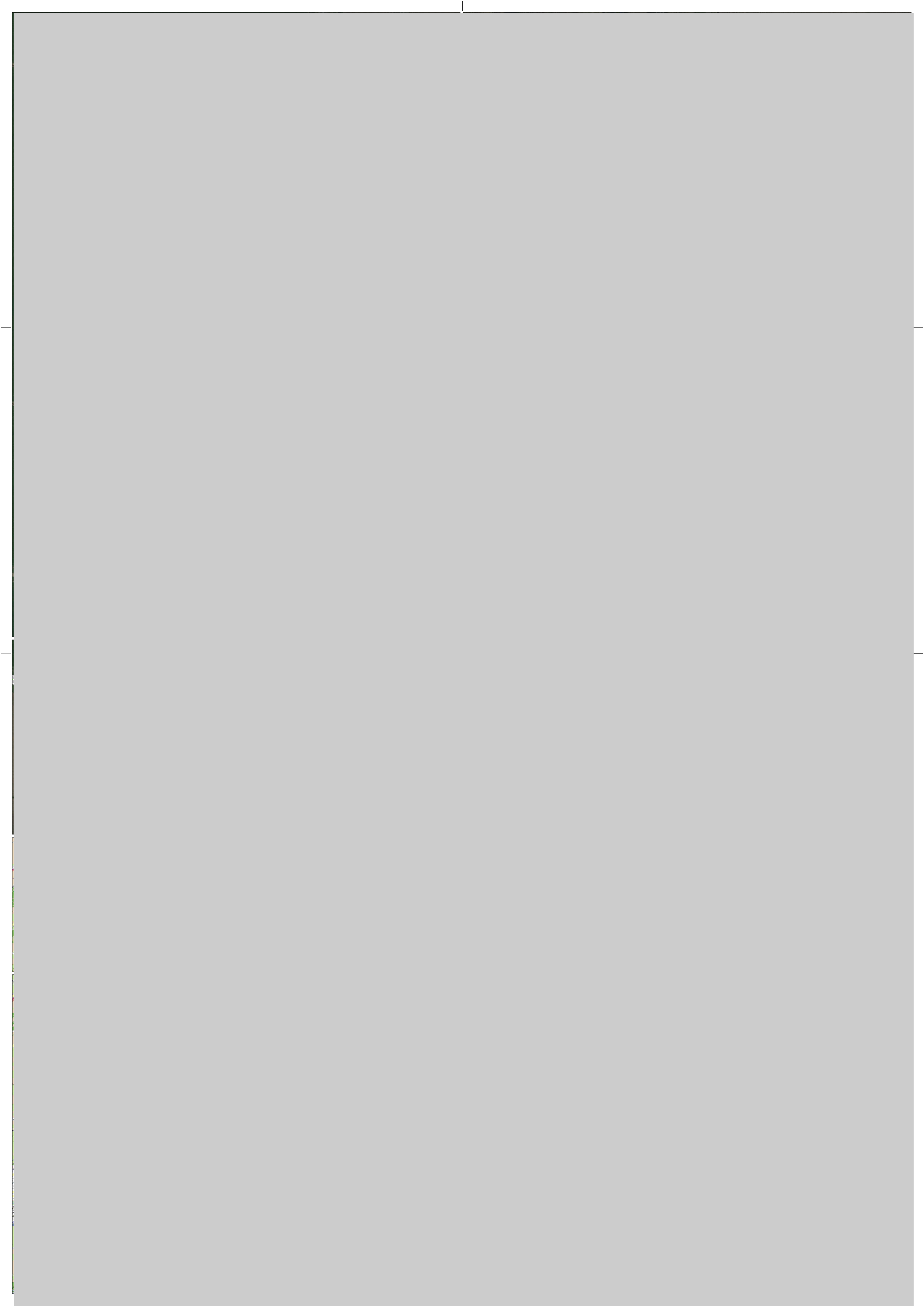



Bijlage XII – Verkeersmaatregelentekeningen maatregel 16

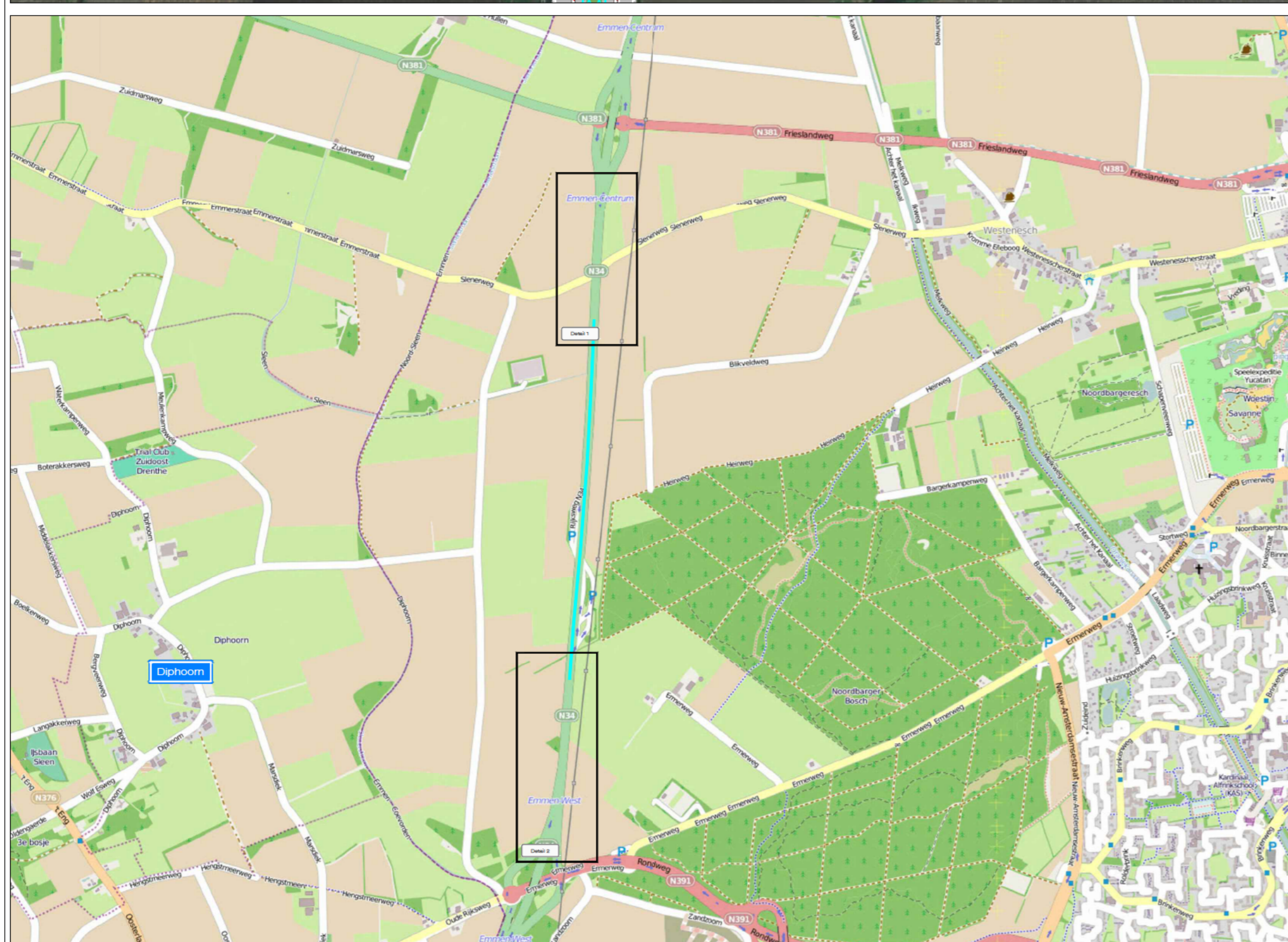

LEGENDA

- Werkvak
- Nieuwe situatie
- Tijdelijke verharding (Dura Vermeer)
- Tijdelijke markering (door derden)
- Alle bebording klasse 2
- Lettertype bebording ANWB Uu
- Letterhoogte Bibeko 10 cm
- Letterhoogte Bubeko 16 cm
- Letterhoogte Autosnelweg 30 cm
- Conflicterende bebording afplakken

OPDRACHTGEVER:	DURA VERMEER Waarmaken van ambities	DATE:	PARAAF:
PROEJECT:	Verdubbeling N34, Emmen West - Aansluiting N381 Fase 2c Werkzaamheden middenberm N34	GET.:	24-10-2019
Vestiging Rijssen: Fahrenheitstraat 13 7461 JA RIJSSSEN	Vestiging Belen: De Hanekampen 17 9411 XN BEILEN	GEZ.:	24-10-2019
Tel.: +31 (0)548 82 09 90 info@savetrafficnederland.nl www.savetrafficnederland.nl		WEG:	
		WEG:	
		PROJECT NR.:	B19-00953
		TEKENING NR.:	STN15
		SCHAAL:	NVT
		FORMAAT:	A1

STN Save Traffic Nederland
Advies, ontwerp en uitvoering tijdelijke verkeersmaatregelen



















[Redacted]

[Redacted]	[Redacted]
[Redacted]	[Redacted]
[Redacted]	[Redacted]

[Redacted]

[Redacted]	[Redacted]	[Redacted]	[Redacted]
[Redacted]	[Redacted]	[Redacted]	[Redacted]
[Redacted]	[Redacted]	[Redacted]	[Redacted]

[Redacted]

[Redacted]

[Redacted]

[Redacted]

[Redacted]

[Redacted]

[Redacted]

[Redacted]

[Redacted]

[Redacted]

[Redacted]

[Redacted]									
[Redacted]	[Redacted]	[Redacted]	[Redacted]	[Redacted]	[Redacted]	[Redacted]	[Redacted]	[Redacted]	[Redacted]
		[Redacted]							

[Redacted]

[Redacted]	[Redacted]	[Redacted]	[Redacted]	[Redacted]	[Redacted]	[Redacted]	[Redacted]	[Redacted]	[Redacted]
------------	------------	------------	------------	------------	------------	------------	------------	------------	------------

		[Redacted]	[Redacted]	[Redacted]	[Redacted]	[Redacted]	[Redacted]	[Redacted]	
--	--	------------	------------	------------	------------	------------	------------	------------	--

[Redacted]									
[Redacted]	[Redacted]	[Redacted]	[Redacted]	[Redacted]	[Redacted]	[Redacted]	[Redacted]	[Redacted]	[Redacted]
		[Redacted]		[Redacted]	[Redacted]	[Redacted]	[Redacted]	[Redacted]	
		[Redacted]		VE-0739	[Redacted]	[Redacted]	[Redacted]	[Redacted]	

[Redacted]									
[Redacted]	[Redacted]	[Redacted]	[Redacted]	[Redacted]	[Redacted]	[Redacted]	[Redacted]	[Redacted]	[Redacted]
[Redacted]	[Redacted]	[Redacted]	[Redacted]	[Redacted]	[Redacted]	[Redacted]	[Redacted]	[Redacted]	[Redacted]
[Redacted]	[Redacted]	[Redacted]	[Redacted]	[Redacted]	[Redacted]	[Redacted]	[Redacted]	[Redacted]	[Redacted]
[Redacted]	[Redacted]	[Redacted]	[Redacted]	[Redacted]	[Redacted]	[Redacted]	[Redacted]	[Redacted]	[Redacted]
[Redacted]	[Redacted]	[Redacted]	[Redacted]	[Redacted]	[Redacted]	[Redacted]	[Redacted]	[Redacted]	[Redacted]
[Redacted]	[Redacted]	[Redacted]	[Redacted]	[Redacted]	[Redacted]	[Redacted]	[Redacted]	[Redacted]	[Redacted]

[Redacted]									
[Redacted]	[Redacted]	[Redacted]	[Redacted]	[Redacted]	[Redacted]	[Redacted]	[Redacted]	[Redacted]	[Redacted]
		[Redacted]							
		[Redacted]		[Redacted]	[Redacted]	[Redacted]	[Redacted]	[Redacted]	
		[Redacted]	[Redacted]	[Redacted]	[Redacted]	[Redacted]	[Redacted]	[Redacted]	
		[Redacted]		[Redacted]	[Redacted]	[Redacted]	[Redacted]	[Redacted]	

[Redacted]									
[Redacted]	[Redacted]	[Redacted]	[Redacted]	[Redacted]	[Redacted]	[Redacted]	[Redacted]	[Redacted]	[Redacted]
[Redacted]	[Redacted]	[Redacted]	[Redacted]	[Redacted]	[Redacted]	[Redacted]	[Redacted]	[Redacted]	[Redacted]
[Redacted]	[Redacted]	[Redacted]	[Redacted]	[Redacted]	[Redacted]	[Redacted]	[Redacted]	[Redacted]	[Redacted]
[Redacted]	[Redacted]	[Redacted]	[Redacted]	[Redacted]	[Redacted]	[Redacted]	[Redacted]	[Redacted]	[Redacted]

[Redacted]									
[Redacted]	[Redacted]	[Redacted]	[Redacted]	[Redacted]	[Redacted]	[Redacted]	[Redacted]	[Redacted]	[Redacted]
		[Redacted]		[Redacted]	[Redacted]	[Redacted]	[Redacted]	[Redacted]	
		[Redacted]		[Redacted]	[Redacted]	[Redacted]	[Redacted]	[Redacted]	
		[Redacted]		[Redacted]	[Redacted]	[Redacted]	[Redacted]	[Redacted]	
		[Redacted]		[Redacted]	[Redacted]	[Redacted]	[Redacted]	[Redacted]	

[Redacted]									
[Redacted]	[Redacted]	[Redacted]	[Redacted]	[Redacted]	[Redacted]	[Redacted]	[Redacted]	[Redacted]	[Redacted]
		[Redacted]		[Redacted]	[Redacted]	[Redacted]	[Redacted]	[Redacted]	
		[Redacted]		[Redacted]	[Redacted]	[Redacted]	[Redacted]	[Redacted]	
		[Redacted]		[Redacted]	[Redacted]	[Redacted]	[Redacted]	[Redacted]	
		[Redacted]		[Redacted]	[Redacted]	[Redacted]	[Redacted]	[Redacted]	

[Redacted]

[Redacted]	[Redacted]	[Redacted]	[Redacted]	[Redacted]	[Redacted]	[Redacted]	[Redacted]	[Redacted]	[Redacted]
------------	------------	------------	------------	------------	------------	------------	------------	------------	------------

[Redacted]	[Redacted]	[Redacted]	[Redacted]	[Redacted]	[Redacted]	[Redacted]	[Redacted]	[Redacted]	[Redacted]
[Redacted]	[Redacted]	[Redacted]	[Redacted]	[Redacted]	[Redacted]	[Redacted]	[Redacted]	[Redacted]	[Redacted]
[Redacted]	[Redacted]	[Redacted]	[Redacted]	[Redacted]	[Redacted]	[Redacted]	[Redacted]	[Redacted]	[Redacted]
[Redacted]	[Redacted]	[Redacted]	[Redacted]	[Redacted]	[Redacted]	[Redacted]	[Redacted]	[Redacted]	[Redacted]

[Redacted]

[Redacted]	[Redacted]	[Redacted]	[Redacted]	[Redacted]	[Redacted]	[Redacted]	[Redacted]	[Redacted]	[Redacted]
------------	------------	------------	------------	------------	------------	------------	------------	------------	------------

[Redacted]	[Redacted]	[Redacted]	[Redacted]	[Redacted]	[Redacted]	[Redacted]	[Redacted]	[Redacted]	[Redacted]
------------	------------	------------	------------	------------	------------	------------	------------	------------	------------

[Redacted]	[Redacted]	[Redacted]	[Redacted]	[Redacted]	[Redacted]	[Redacted]	[Redacted]	[Redacted]	[Redacted]
------------	------------	------------	------------	------------	------------	------------	------------	------------	------------

[Redacted]	[Redacted]	[Redacted]	[Redacted]	[Redacted]	[Redacted]	[Redacted]	[Redacted]	[Redacted]	[Redacted]
------------	------------	------------	------------	------------	------------	------------	------------	------------	------------

[Redacted]

[Redacted]	[Redacted]	[Redacted]	[Redacted]	[Redacted]	[Redacted]	[Redacted]	[Redacted]	[Redacted]	[Redacted]
------------	------------	------------	------------	------------	------------	------------	------------	------------	------------

		[Redacted]							
--	--	------------	--	--	--	--	--	--	--

		[Redacted]		[Redacted]	[Redacted]	[Redacted]		[Redacted]	[Redacted]
--	--	------------	--	------------	------------	------------	--	------------	------------

		[Redacted]	[Redacted]	[Redacted]	[Redacted]	[Redacted]	[Redacted]		
--	--	------------	------------	------------	------------	------------	------------	--	--

[Redacted]									
[Redacted]	[Redacted]	[Redacted]	[Redacted]	[Redacted]	[Redacted]	[Redacted]	[Redacted]	[Redacted]	[Redacted]
[Redacted]	[Redacted]	[Redacted]	[Redacted]	[Redacted]	[Redacted]	[Redacted]	[Redacted]	[Redacted]	[Redacted]
		[Redacted]	[Redacted]	[Redacted]	[Redacted]	[Redacted]	[Redacted]	[Redacted]	[Redacted]
		[Redacted]	[Redacted]	[Redacted]	[Redacted]	[Redacted]	[Redacted]	[Redacted]	[Redacted]
		[Redacted]	[Redacted]	[Redacted]	[Redacted]	[Redacted]	[Redacted]	[Redacted]	[Redacted]

[Redacted]									
[Redacted]	[Redacted]	[Redacted]	[Redacted]	[Redacted]	[Redacted]	[Redacted]	[Redacted]	[Redacted]	[Redacted]
[Redacted]	[Redacted]	[Redacted]	[Redacted]	[Redacted]	[Redacted]	[Redacted]	[Redacted]	[Redacted]	[Redacted]
[Redacted]	[Redacted]	[Redacted]	[Redacted]	[Redacted]	[Redacted]	[Redacted]	[Redacted]	[Redacted]	[Redacted]
[Redacted]	[Redacted]	[Redacted]	[Redacted]	[Redacted]	[Redacted]	[Redacted]	[Redacted]	[Redacted]	[Redacted]

[Redacted]									
[Redacted]	[Redacted]	[Redacted]	[Redacted]	[Redacted]	[Redacted]	[Redacted]	[Redacted]	[Redacted]	[Redacted]
[Redacted]	[Redacted]	[Redacted]	[Redacted]	[Redacted]	[Redacted]	[Redacted]	[Redacted]	[Redacted]	[Redacted]
		[Redacted]	[Redacted]	[Redacted]	[Redacted]	[Redacted]	[Redacted]	[Redacted]	[Redacted]
		[Redacted]	[Redacted]	[Redacted]	[Redacted]	[Redacted]	[Redacted]	[Redacted]	[Redacted]
		[Redacted]	[Redacted]	[Redacted]	[Redacted]	[Redacted]	[Redacted]	[Redacted]	[Redacted]



